

Your Source For:

GENUINE STONE 

- Caesarstone®
- Difiniti™
- Dupont Zodiaq®
- Hanstone™
- Rinato
- Radianz™
- Silestone



Magnum 801 Series Granite Composite Sink

Undercounter Double Bowl (Large Bowl on Left)

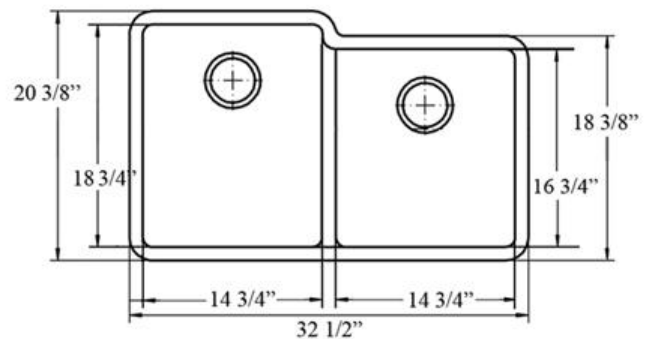

Description

Overall Size 32 1/2" x 20 3/8" x 9 1/2"

Heat Resistant to 550 Degrees

Silver Ions Added - Kills 99% of Bacteria on Contact

All Natural Materials - Environmentally Friendly and Recyclable

Acrylic Acts as Natural Sound Dampener; No Pads Needed

Extremely Scratch Resistant

Lifetime Warranty

Colors Available: Black, Brown, Beige and White

Finish

Made with 80% Quartzite, 20% Acrylic
Completely Stain Resistant Material - Unaffected by Household Acids or Cleaners

Installation

Undercounter Installation.
Undermount Granite Sink Clip Hardware Included
Offset Drain 3 1/2" (114 mm) Drain Opening

Sink Strainer/Drain Assembly Sold Separately

X:\forms\magnum801series_specs.docx

5760 Quam Avenue N.E. • St. Michael, MN 55376 • Phone: (763) 428-4075 • Fax: (763) 428-1795
www.paramountgranite.com • E-Mail: info@paramountgranite.com

